

# TWIN FU-NUT Dimension Table

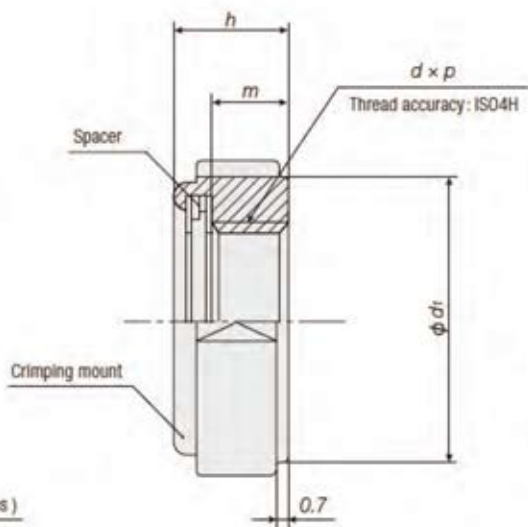
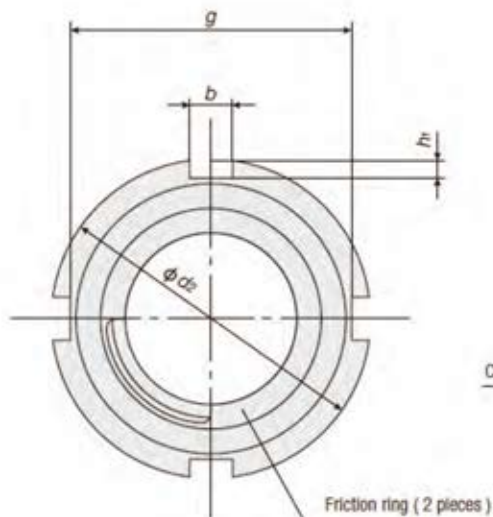

## Material

Nut body : S45C ( Heat Treated )  
 Friction ring : SUS301  
 Spacer : SUS301  
 Surface treatment : Phosphate conversion coating

\* Simultaneous processing of the thread and the bearing surface

Thread accuracy: ISO4H Unit: mm

Part No.	Designation of Thread d×p	φ d <sub>1</sub>	φ d <sub>2</sub>	h	m	b	h <sub>1</sub>	g	Thread accuracy length ℓ min	Unit Weight (g)	Allowable axial dead load (kN)
TFU02SC	M15×1	21.0	25	9.9	7	4	1.8	21.4	10.5	19	34.1
TFU03SC	M17×1	23.5	28	10.1	7	4	2.0	24	10.5	24	38.6
TFU04SC	M20×1	27	32	12.3	9	4	2.0	28	12.5	38	59.4
TFU05SC	M25×1.5	33	38	14.2	10	5	2.0	34	15.3	59	80.8
TFU06SC	M30×1.5	40	45	14.3	10	5	2.0	41	15.3	82	97.0
TFU07SC	M35×1.5	47	52	16.5	12	5	2.0	48	17.3	125	137.8
TFU08SC	M40×1.5	52	58	17.6	13	6	2.5	53	18.3	150	171.4
TFU09SC	M45×1.5	59	65	19.7	15	6	2.5	60	20.3	210	224.5
TFU10SC	M50×1.5	64	70	20.8	16	6	2.5	65	21.3	255	266.8

\* Specify Part No. when placing an order.